



MAX1537 Evaluation Kit

Evaluates: MAX1537

General Description

The MAX1537 evaluation kit (EV kit) demonstrates the MAX1537's standard application circuit. This dual PWM synchronous DC-DC converter steps down high-voltage batteries and/or AC adapters, generating main supplies for notebook computers. The MAX1537 EV kit provides dual 5V and 3.3V output voltages from a 6V to 24V battery input range. It delivers up to 6A output current for the 5V output and 6A for the 3.3V output with 97% efficiency. Both outputs are adjustable between 1V and 5.5V by changing feedback resistors R19–R22.

A transformer on the 5V output generates a 12V auxiliary voltage capable of delivering 150mA. This auxiliary voltage is adjustable between 5V and 23V by changing feedback resistors R17 and R18.

The MAX1537 also has an internal fixed 3.3V and 5V linear regulator both capable of supplying 100mA.

The MAX1537 EV kit operates at 300kHz switching frequency.

Features

- ◆ 6V to 24V Input Range
- ◆ Internal 5V and 3.3V Linear Regulators with 100mA Load Capability
- ◆ Output Voltages
 - 3.3V at 6A (Adjustable from 1V to 5.5V)
 - 5V at 6A (Adjustable from 1V to 5.5V)
 - 12V at 150mA (Adjustable from 5V to 23V)
- ◆ 300kHz Switching Frequency (Selectable 200kHz/300kHz/500kHz)
- ◆ Power-Good Output
- ◆ Selectable Over- and Undervoltage Protection
- ◆ 36-Pin Thin QFN Package
- ◆ Fully Assembled and Tested

Ordering Information

PART	TEMP RANGE	IC PACKAGE
MAX1537EVKIT	0°C to +70°C	36 Thin QFN

Component List

DESIGNATION	QTY	DESCRIPTION
C1, C2, C3	3	10 μ F, 25V, X7R, \pm 10%, 1812 ceramic capacitors TDK C4532X7R1E106K
C4, C7	0	Not installed, D-size
C5	1	150 μ F, 6.3V, 25m Ω , \pm 20%, POSCAP/KO-CAP Kemet T520D157M006ASE025 Sanyo 6TPE150M
C6	1	220 μ F, 6.3V, 25m Ω , \pm 20%, POSCAP/KO-CAP Kemet T520V227M006ASE025 Sanyo 6TPE220M
C8	1	22 μ F, 35V, \pm 20%, SMD 5mm x 6mm, aluminum electrolytic capacitor Panasonic EEVFK1V220R Sanyo 35CV22AX
C9, C11, C18	3	1 μ F, 10V, X5R, \pm 10%, 0603 ceramic capacitors Murata GRM188R61A105K TDK C1608X5R1A105K
C10, C17, C22	3	0.1 μ F, 25V, X7R, \pm 10%, 0603 ceramic capacitors Murata GRM188R71E104K TDK C1608X7R1E104K

DESIGNATION	QTY	DESCRIPTION
C12	1	0.22 μ F, 16V, X7R, \pm 10%, 0603 ceramic capacitor Murata GRM188R71E224K TDK C1608X7R1C224K
C13	1	0.022 μ F, 50V, X7R, \pm 10%, 0603 ceramic capacitor Murata GRM188R71H223K TDK C1608X7R1H223K
C15, C19	2	10 μ F, 6.3V, X5R, 20%, 0805 ceramic capacitors Murata GRM21BR60J106M TDK C2012X5R0J106M
C21	1	10 μ F, 35V, \pm 20%, SMD 5mm x 6mm, aluminum electrolytic capacitor Panasonic EEVFK1V100R Sanyo 35CV10AX
C23	1	4.7 μ F, 25V, X7R, \pm 10%, 1210 ceramic capacitor TDK C3225X7R1E475K
C24, C25	0	Not installed, 0603
D1, D2	2	Schottky diodes, 2A, 30V, SMA Central Semiconductor CMSH2-40M Diodes Inc. B230A

MAX1537 Evaluation Kit

Component List (continued)

DESIGNATION	QTY	DESCRIPTION
D3, D5	2	Schottky diodes, 0.1A, 30V, SOD123 Central Semiconductor CMHSH-3 Diodes Inc. BAT43W Vishay Semiconductors BAT43W
D4	1	Fast recovery diode, 1A, 200V, SMB Central Semiconductor CMR1S-02 Diodes Inc. MURS120 Vishay Semiconductors MURS120
JU1–JU7	7	3-pin headers, 0.1in center
JU9–JU15	0	Not installed, 2-pin jumpers, 0603
L2	1	5.8 μ H, 8.6A, 16.2m Ω , inductor Sumida CDRH127/LD-5R8NC
N1, N3	2	MOSFETs, n-channel, 8.4A, 30V, SO8 Fairchild FDS6612A
N2, N4	2	MOSFETs, n-channel, 13A, 30V, SO8 Fairchild FDS6670A

DESIGNATION	QTY	DESCRIPTION
R1, R2	2	0.01 Ω \pm 1%, 0.5W, 2010, sense resistors IRC LRC-LRF2010-01-R010-F Vishay Dale WSL2010 0.010 1.0%
R3	1	20 Ω \pm 5%, 0603 resistor
R4–R12, R16–R24	0	Not installed, 0603
R14	1	100k Ω \pm 5%, 0603 resistor
R15	0	Not installed, 1206
T1	1	Transformer, primary 6.8 μ H, 6.4A, 1:2 Sumida 4749-T132 (CDRH127B style)
U1	1	MAX1537ETX, 36-pin, 6mm x 6mm, thin QFN
None	1	PC board MAX1537 EV kit
None	7	Shunts

Component Suppliers

SUPPLIER	PHONE	FAX	WEBSITE
Central Semiconductor	631-435-1110	631-435-1824	www.centralsemi.com
Diodes Inc.	805-446-4800	805-446-4850	www.diodes.com
Fairchild Semiconductor	888-522-5372	—	www.fairchildsemi.com
IRC (International Resistive Company)	361-992-7900	361-992-3377	www.irctt.com
Kemet	864-963-6300	864-963-6322	www.kemet.com
Murata	770-436-1300	770-436-3030	www.murata.com
Panasonic	714-373-7366	714-737-7323	www.panasonic.com
Sanyo	619-661-6835	619-661-1055	www.sanyodevice.com
Sumida	847-545-6700	847-545-6720	www.sumida.com
TDK	847-803-6100	847-390-4405	www.component.tdk.com
Vishay	402-564-3131	402-563-6296	www.vishay.com

Note: Indicate you are using the MAX1537 when contacting these manufacturers.

Quick Start

Recommended Equipment

Before beginning, the following equipment is recommended:

- A 6V to 24V, 100W, DC power supply
- Dummy loads capable of sinking 6A
- 3 voltmeters
- An oscilloscope

Procedure

The MAX1537 EV kit is a fully assembled and tested surface-mount board. Follow the steps below to verify

board operation. **Do not turn on the power supply until all connections are completed.**

- 1) Verify that the shunts are in the following positions:
 - JU1 = 1-2 (overvoltage protection disabled)
 - JU2 = 1-2 (MAX1537 enabled)
 - JU3 = 1-2 (undervoltage protection disabled)
 - JU4 = 1-2 (PWM mode)
 - JU5 = 1-2 (5V main output enabled)
 - JU6 = 1-2 (3.3V main output enabled)
 - JU7 = 1-2 (12V auxiliary output enabled)
- 2) Connect the power supply across the VIN and PGND pads.

MAX1537 Evaluation Kit

Evaluates: MAX1537

- 3) Connect a voltmeter across the 5V_MAIN and PGND pads.
- 4) Connect a voltmeter across the 3.3V_MAIN and PGND pads.
- 5) Connect a voltmeter across the 12V and GND pads.
- 6) Turn on the power supply.
- 7) Verify the voltages.

Detailed Description

3.3V_MAIN Output Voltage Setting

The MAX1537 EV kit is shipped with FB3 connected to GND, which sets the 3.3V_MAIN voltage to 3.3V.

To change the output voltage to a value between 1V and 5.5V, set R20 equal to $10k\Omega \pm 1\%$, and calculate R19 using the equation $R19 = R20 [(V_{OUT} / V_{FB3}) - 1]$, where $V_{FB3} = 1V$.

For an output voltage of 1V, place a short across R19 and leave R20 open.

5V_MAIN Output Voltage Setting

The MAX1537 EV kit is shipped with FB5 connected to GND, which sets the 5V_MAIN voltage to 5V.

To change the output voltage to a value between 1V and 5.5V, set R22 equal to $10k\Omega \pm 1\%$, and calculate R21 using the equation $R21 = R22 [(V_{OUT} / V_{FB5}) - 1]$, where $V_{FB5} = 1V$.

For an output voltage of 1V, place a short across R21 and leave R22 open.

Table 1. Jumper Selection

FUNCTION	JUMPER	JUMPER POSITION	DESCRIPTION
\overline{OVP}	JU1	1-2*	Disables overvoltage protection.
		2-3	Enables overvoltage protection.
\overline{SHDN}	JU2	1-2*	Enables the MAX1537.
		2-3	Places the MAX1537 in shutdown.
\overline{UVP}	JU3	1-2*	Disables undervoltage protection.
		2-3	Enables undervoltage protection.
\overline{SKIP}	JU4	1-2*	Places the MAX1537 in low-noise, forced-PWM mode.
		2-3	Place the MAX1537 in high-efficiency pulse-skipping mode at light loads.
ON5	JU5	1-2*	Enables the 5V main output.
		2-3	Disables the 5V main output.
ON3	JU6	1-2*	Enables the 3.3V main output.
		2-3	Disables the 3.3V main output.
ONA	JU7	1-2*	Enables the 12V auxiliary output.
		2-3	Disables the 12V auxiliary output.

*Default position.

LDOA (12V Auxiliary) Output Voltage Setting

The MAX1537 EV kit is shipped with ADJA connected to GND, which sets the LDOA voltage to 12V.

To change the output voltage to a value between 5V and 23V, set R18 equal to $10k\Omega \pm 1\%$, and calculate R17 using the equation $R17 = R18 [(V_{OUT} / V_{ADJA}) - 1]$, where $V_{ADJA} = 2V$.

Frequency Selection

The MAX1537 operates at 200kHz/300kHz/500kHz switching frequency. The EV kit is shipped with the frequency set to 300kHz. To use a different frequency, cut the trace shorting JU14 and install a short across JU13 for 500kHz or JU15 for 200kHz (see Table 2).

Table 2. Frequency Selection

FREQUENCY	JUMPER POSITIONS		
	JU13	JU14	JU15
200kHz	OPEN	OPEN	SHORT
300kHz*	OPEN*	SHORT*	OPEN*
500kHz	SHORT	OPEN	OPEN

*Default setting.

Note: Do not change the operating frequency without first recalculating component values, because the frequency has a significant effect on preferred inductor value, peak current-limit level, MOSFET heating, PFM/PWM switchover point, output noise, efficiency, and other critical parameters.

MAX1537 Evaluation Kit

Evaluates: MAX1537

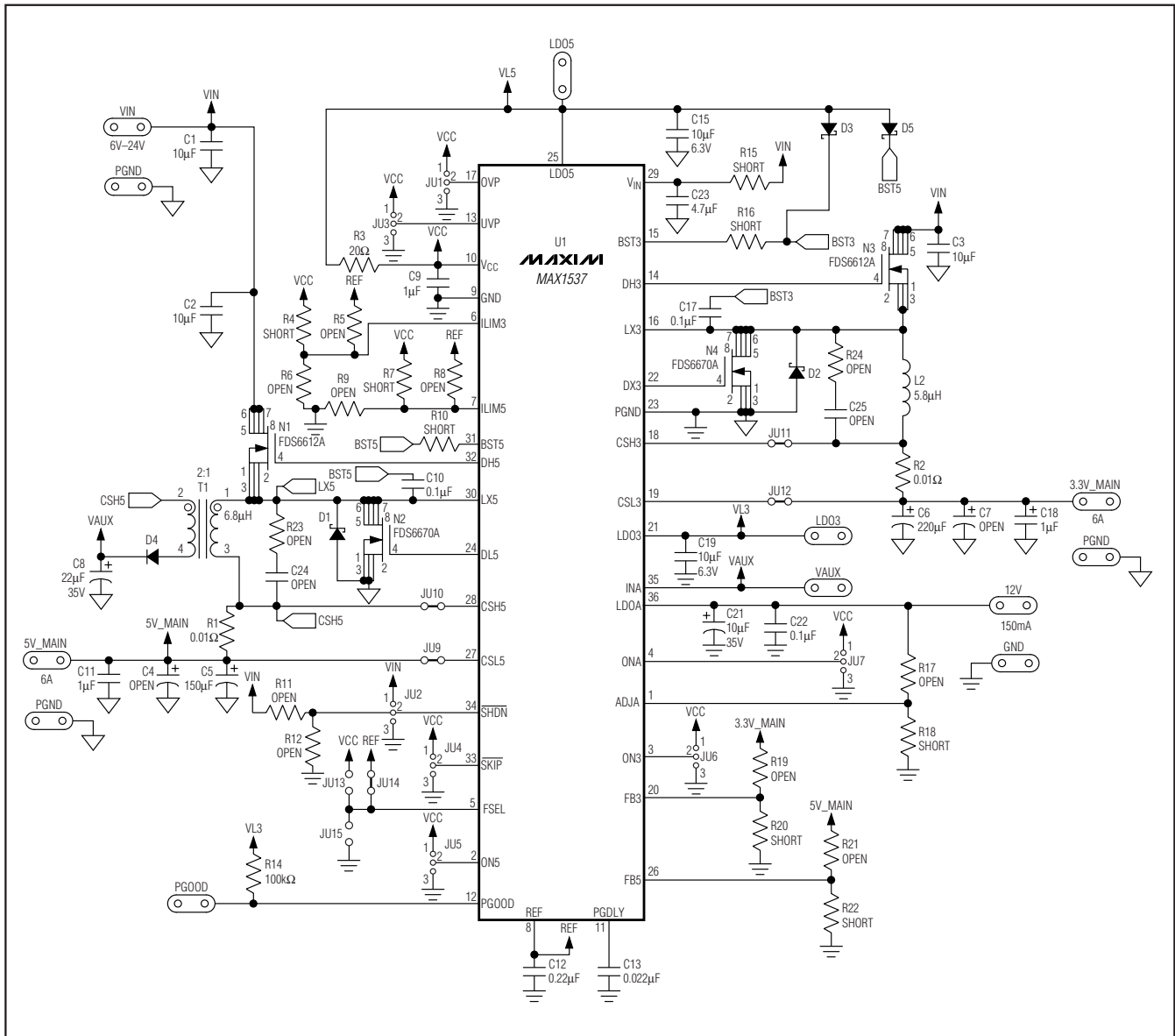

Figure 1. MAX1537 EV Kit Schematic

MAX1537 Evaluation Kit

Evaluates: MAX1537

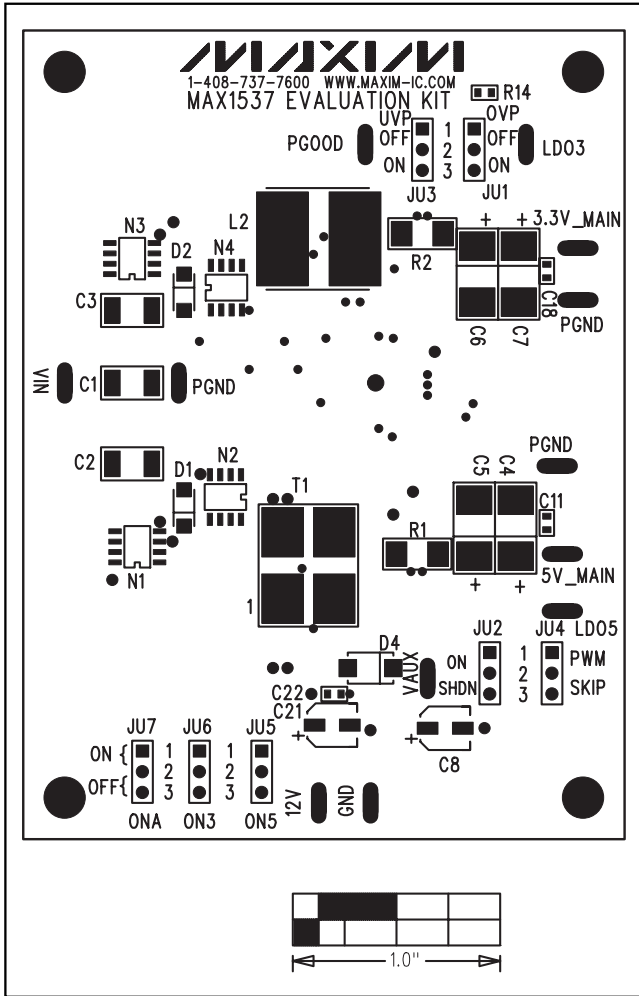

Figure 2. MAX1537 EV Kit Component Placement Guide—Component Side

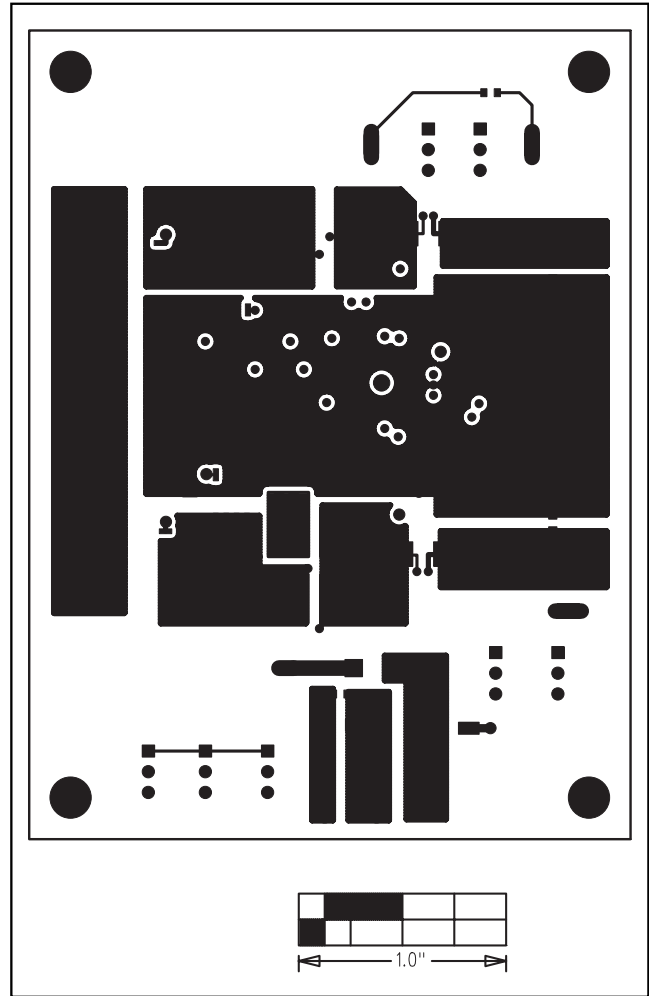

Figure 3. MAX1537 EV Kit PC Board Layout—Component Side

MAX1537 Evaluation Kit

Evaluates: MAX1537

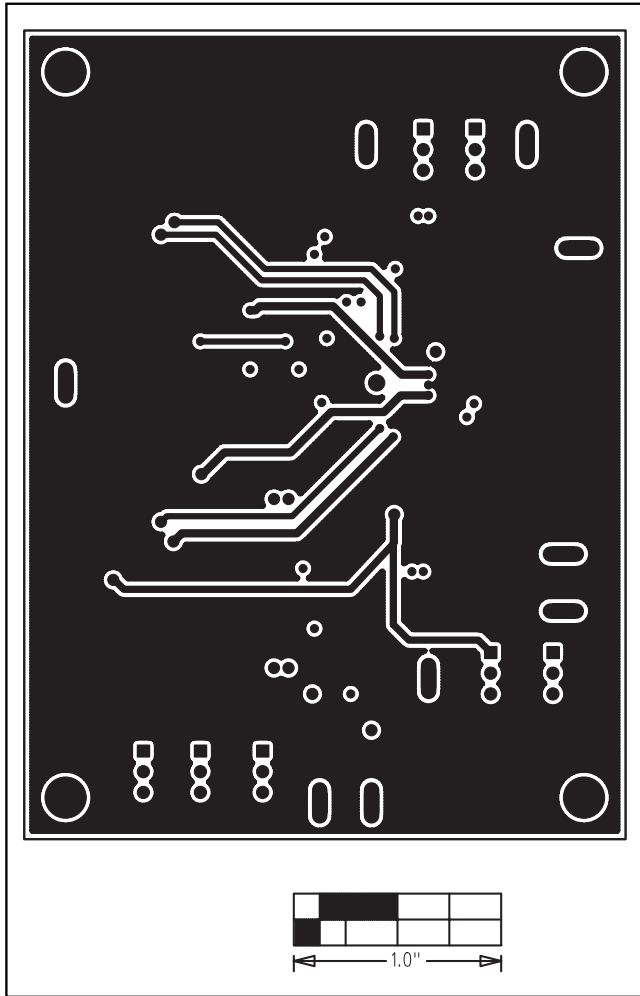

Figure 4. MAX1537 EV Kit PC Board Layout—Layer 2

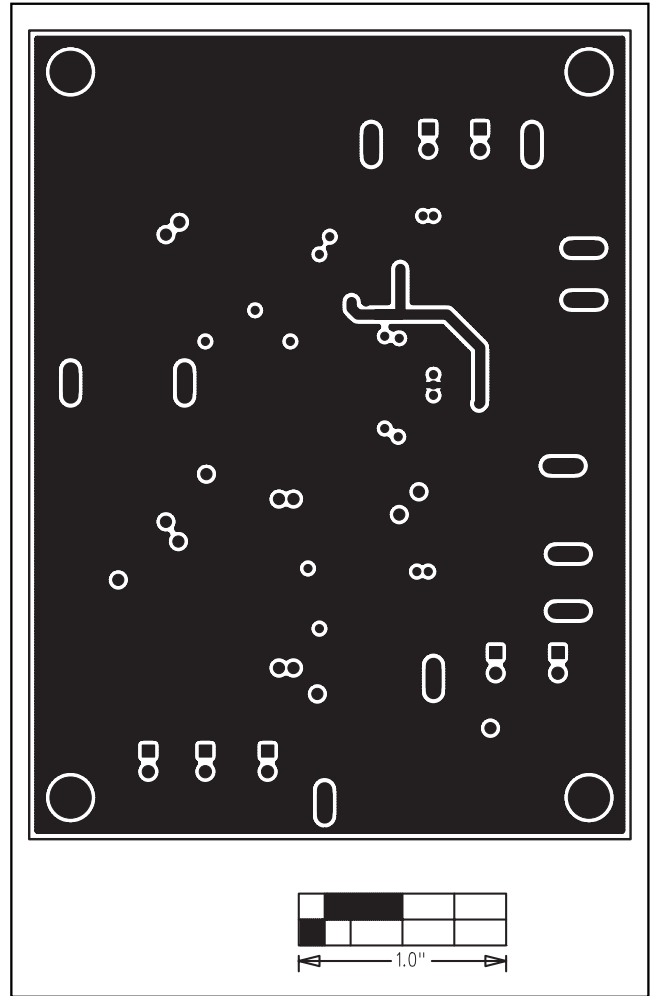

Figure 5. MAX1537 EV Kit PC Board Layout—Layer 3

MAX1537 Evaluation Kit

Evaluates: MAX1537

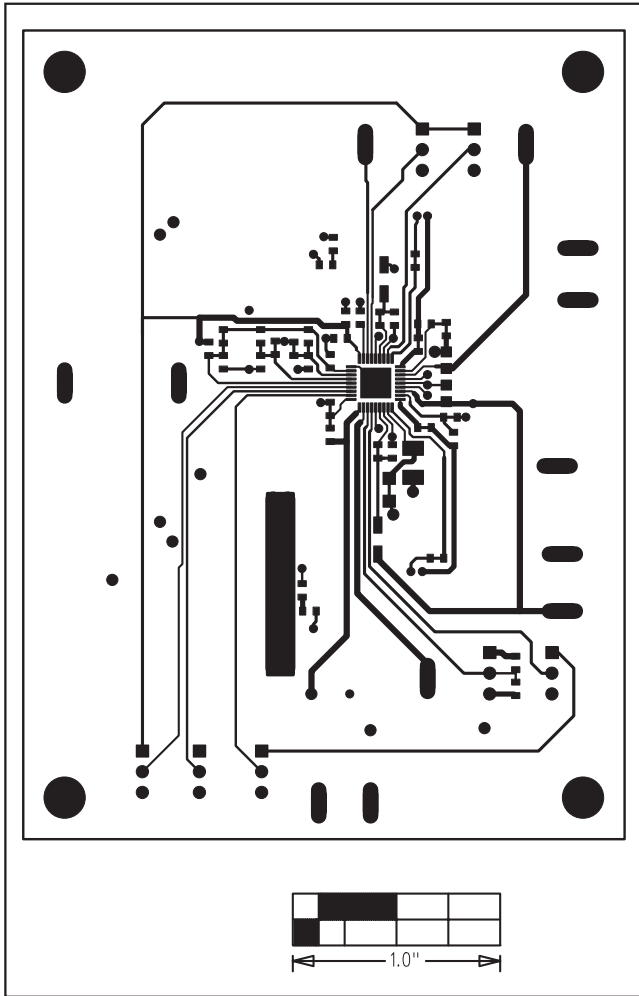

Figure 6. MAX1537 EV Kit PC Board Layout—Solder Side

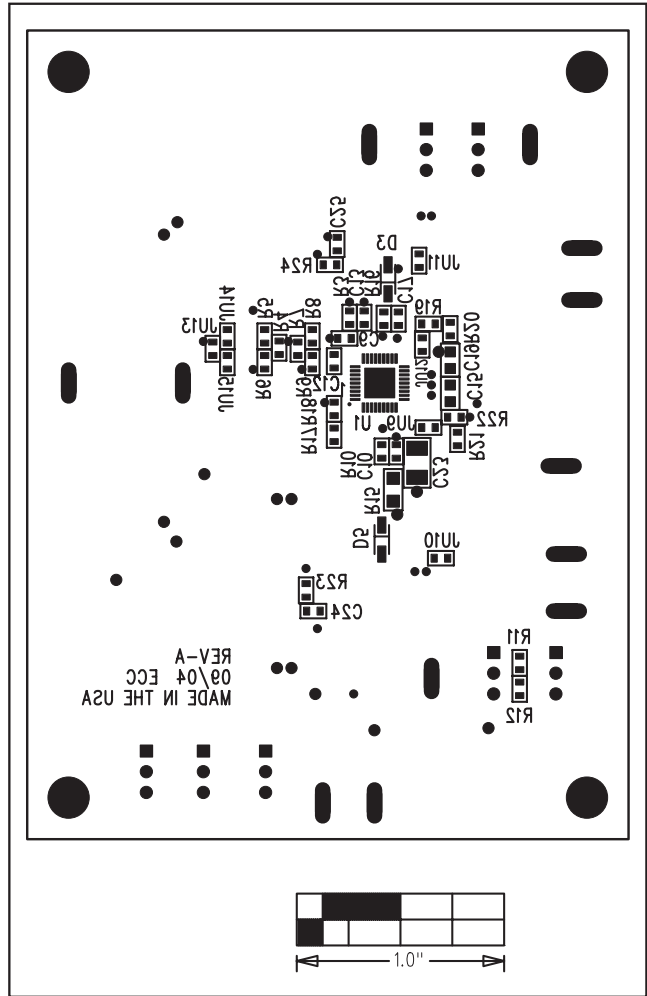

Figure 7. MAX1537 EV Kit Component Placement Guide—Solder Side

Maxim cannot assume responsibility for use of any circuitry other than circuitry entirely embodied in a Maxim product. No circuit patent licenses are implied. Maxim reserves the right to change the circuitry and specifications without notice at any time.

Maxim Integrated Products, 120 San Gabriel Drive, Sunnyvale, CA 94086 408-737-7600 _____ 7